

Basal Ganglia

Emo Todorov

Applied Mathematics
Computer Science and Engineering

University of Washington

Loops with cortex

2

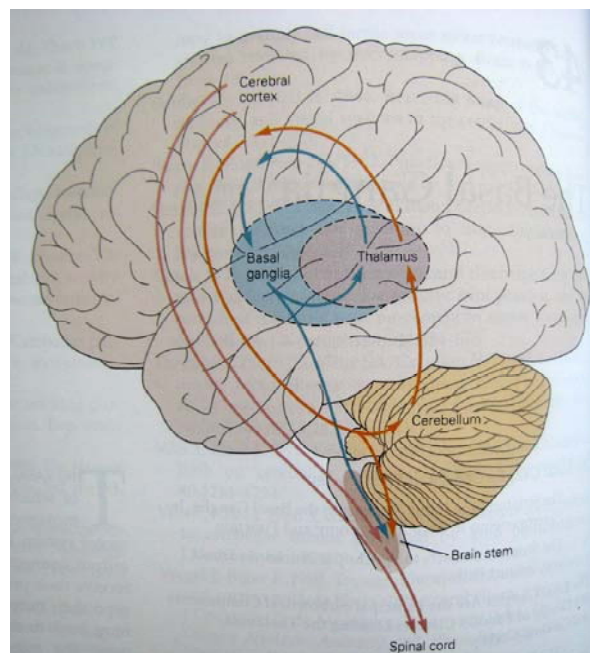

Subdivisions

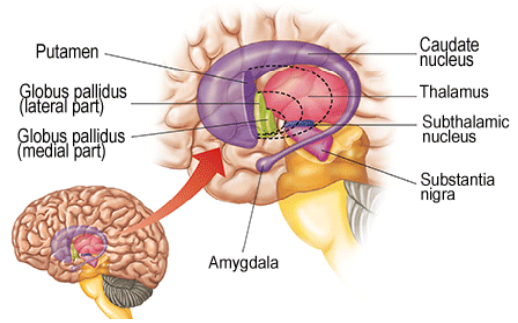
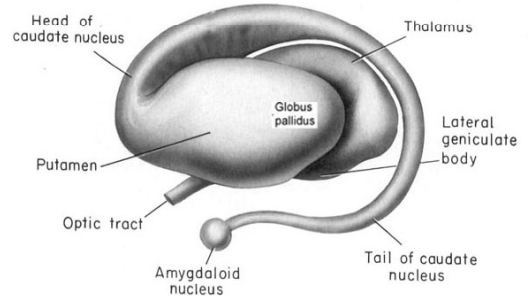
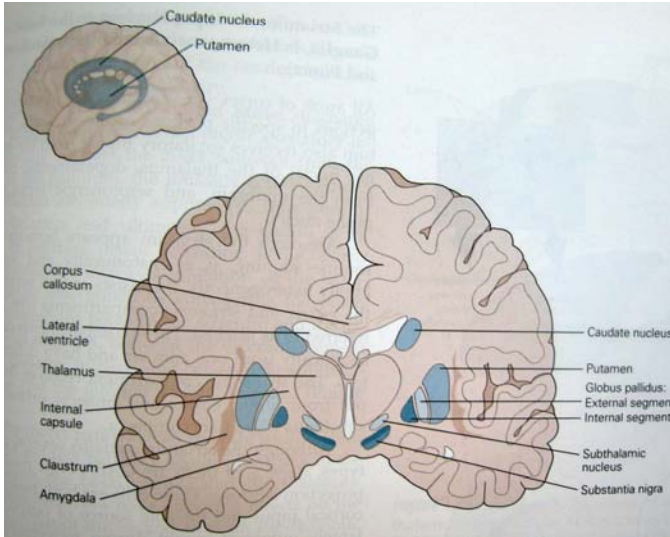

Circuit diagram

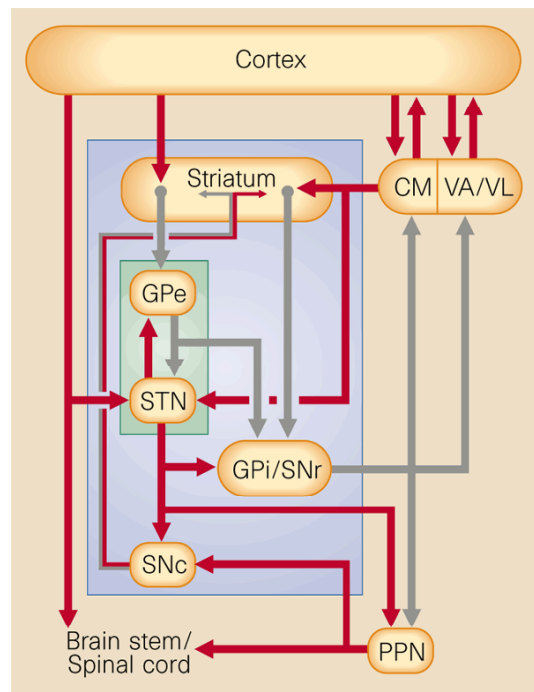
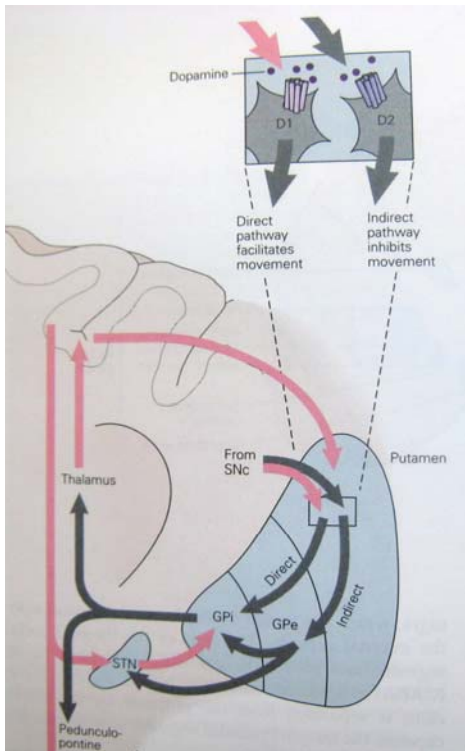

Cortical targets

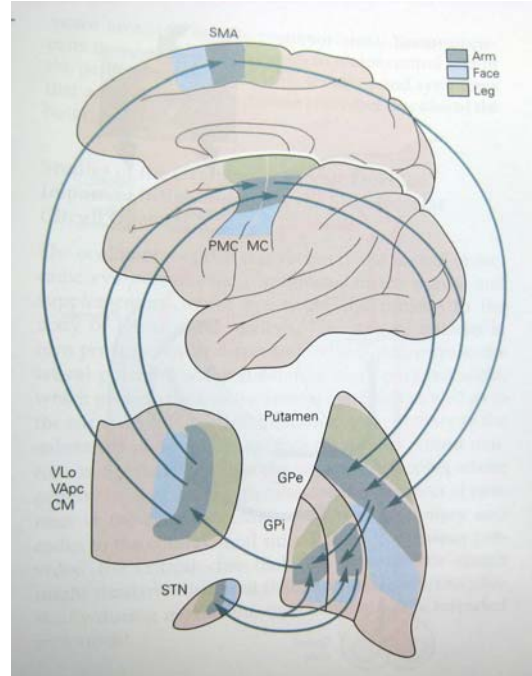
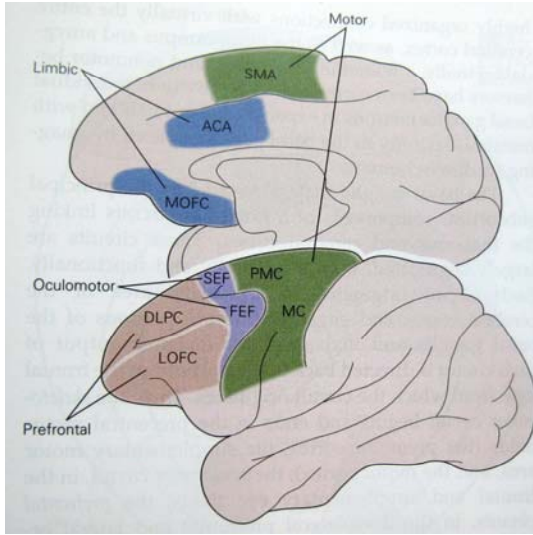

Specificity or recurrent connections

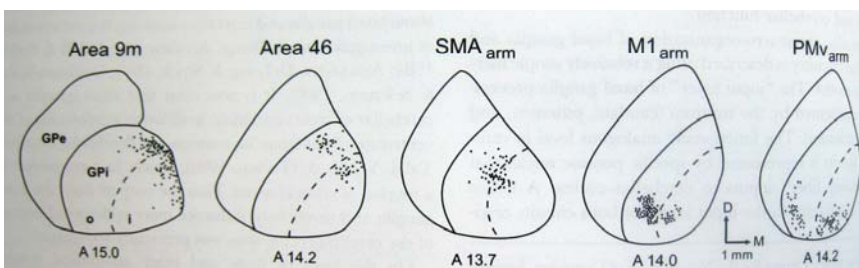
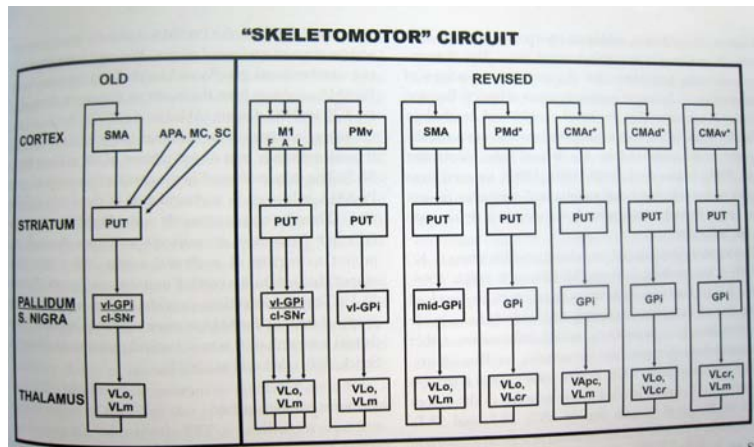
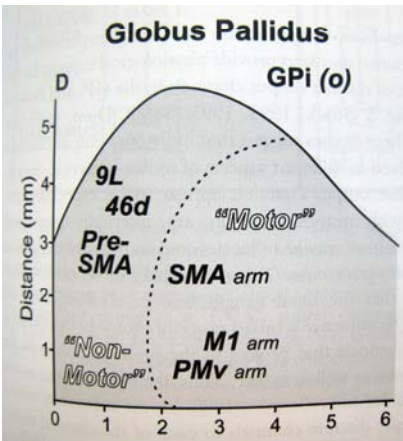

Imbalance of excitation and inhibition

7

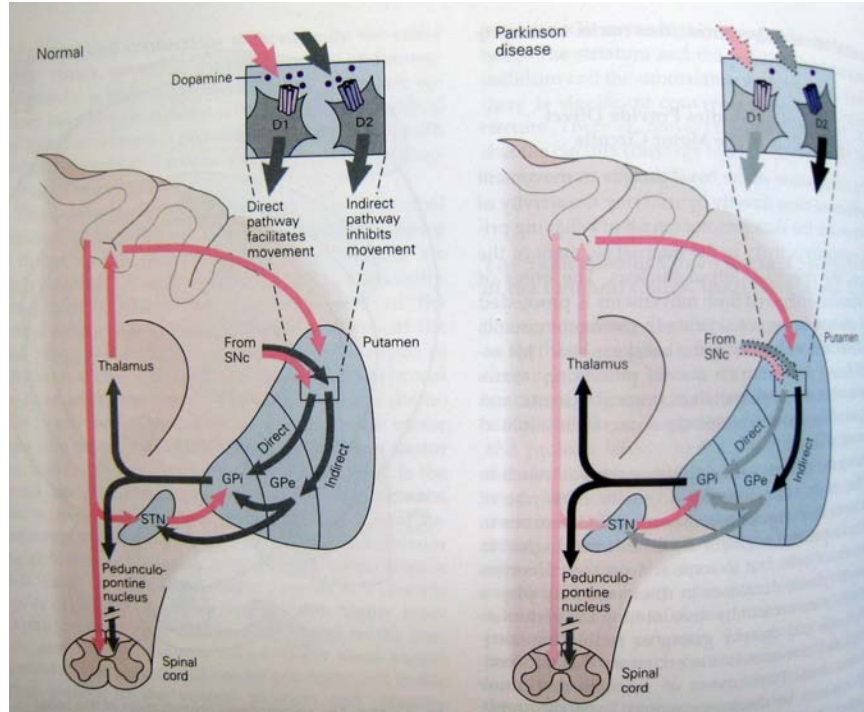

Parkinson's movements are mostly normal

8

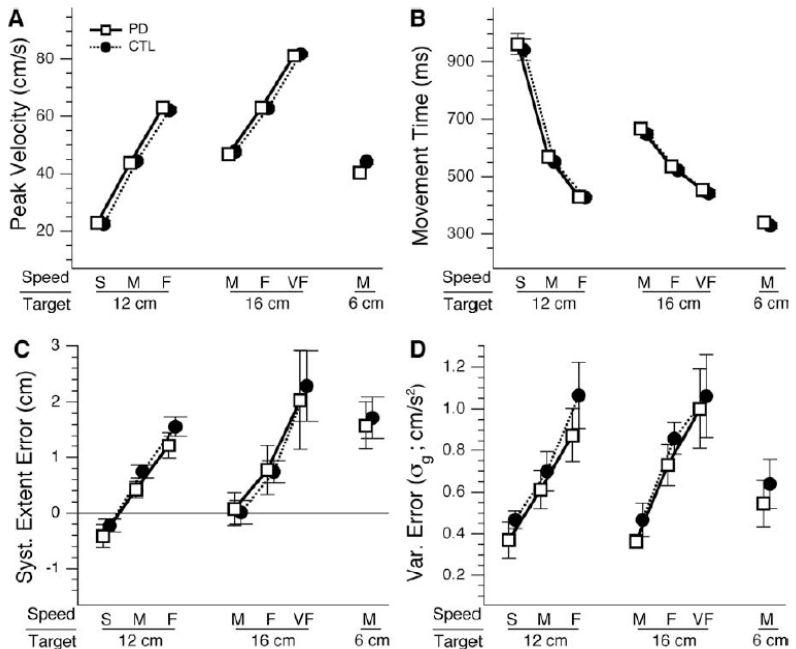
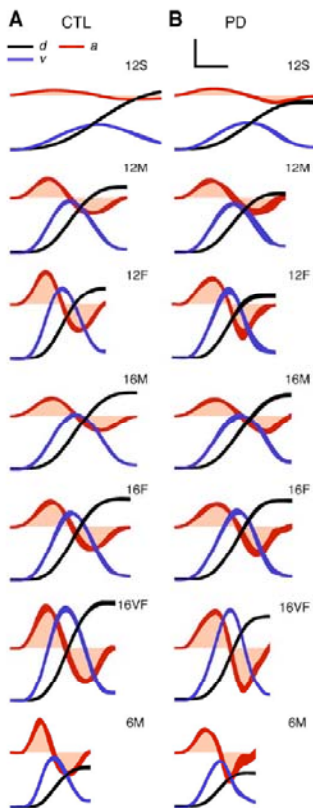

Imbalance of excitation and inhibition

9

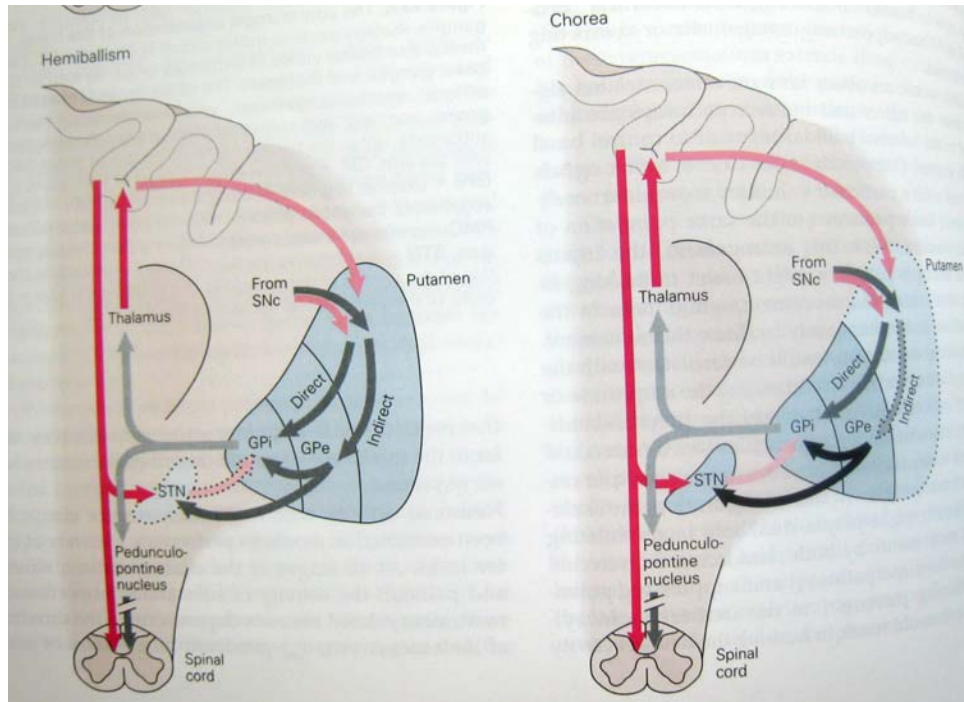

Broad suppression and local facilitation

10

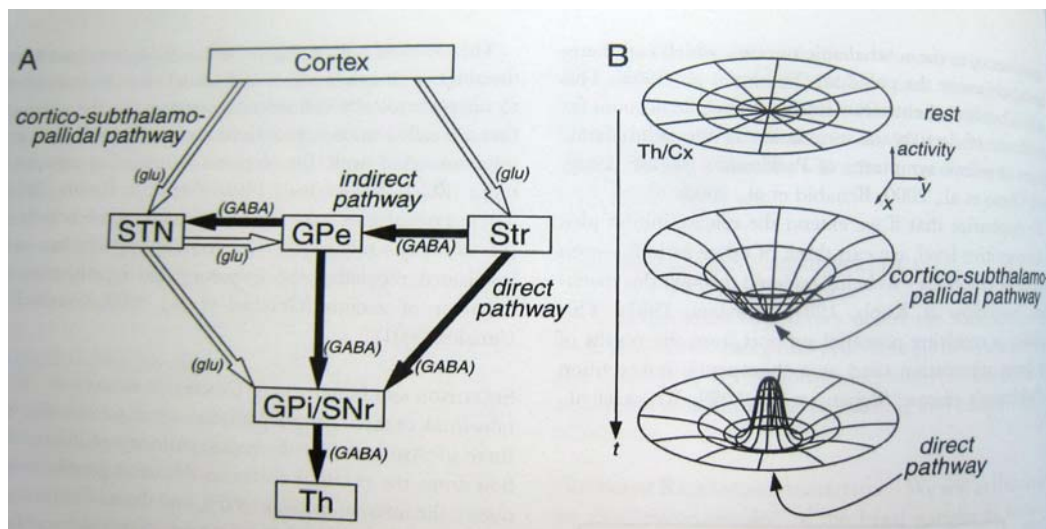

Coding of reward by dopamine neurons

11

(Schultz)

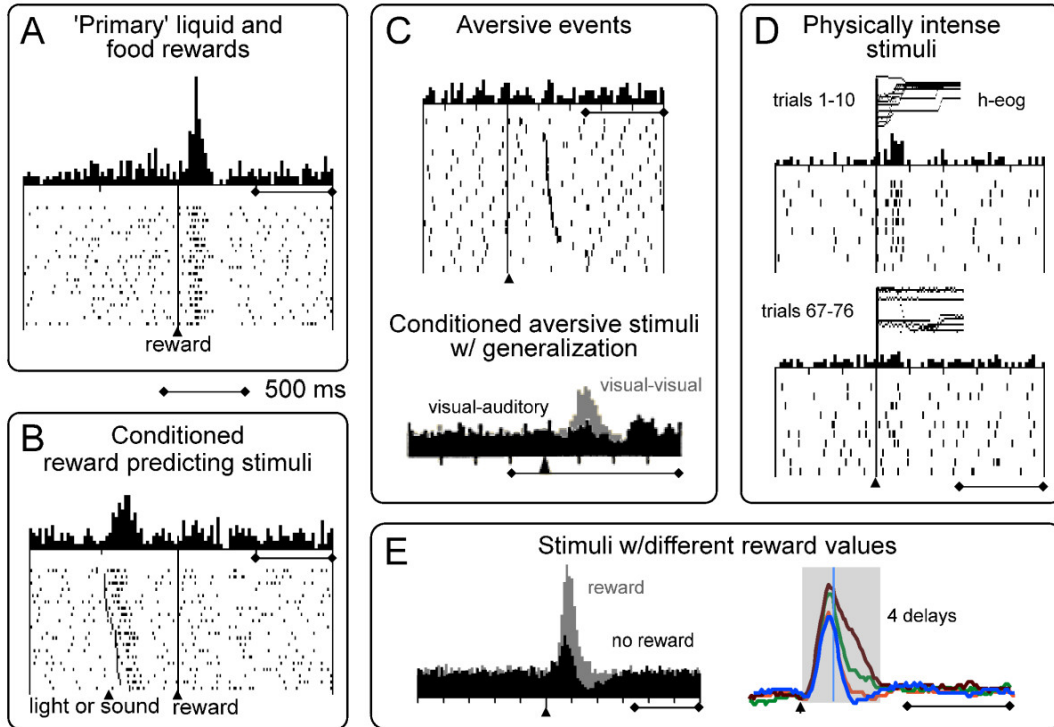

Coding of relative reward magnitude

12

